

Primer on Medical Decision Analysis:

Part 2—Building a Tree

ALLAN S. DETSKY, MD, PhD, GARY NAGLIE, MD,
MURRAY D. KRAHN, MD, MSc, DONALD A. REDELMEIER, MD, MS(HSR),
DAVID NAIMARK, MD

This part of a five-part series covering practical issues in the performance of decision analysis outlines the basic strategies for building decision trees. The authors offer six recommendations for building and programming decision trees. Following these six recommendations will facilitate performance of the sensitivity analyses required to achieve two goals. The first is to find modeling or programming errors, a process known as “debugging” the tree. The second is to determine the robustness of the qualitative conclusions drawn from the analysis. *Key words:* decision analysis; expected value; utility; sensitivity analysis; decision trees; probability. (*Med Decis Making* 1997;17:126–135)

Software

We teach students to build their trees using SMLTREE, a DOS-based software package (SMLTREE. Hollenberg JP. Version 2.9. Roslyn, NY). Though many other software packages (e.g., DECISION MAKER, Pratt Medical Group, Boston, MA) are available, SMLTREE is widely used by practitioners as well as students of decision analysis and comes with an excellent tutorial teaching the students the nuts and bolts of programming a tree. Because this series is intended to be a practical “how to” guide, some of the discussion, particularly the discussion related to debugging the tree, is not directly applicable to solving decision problems using spreadsheets, influence diagrams, or other software packages.

Decision Analysis Example: Giant Cell Arteritis

We use one clinical scenario throughout the rest of the series: the choice of management strategies

Received November 27, 1995, from the University of Toronto Programme in Clinical Epidemiology and Health Care Research (The Toronto Hospital and The Sunnybrook Health Science Centre Units) and the Departments of Health Administration, Medicine, and Clinical Biochemistry, Toronto, Ontario, Canada. Revision accepted for publication December 12, 1996. Drs. Detsky and Redelmeier are partially supported by Career Awards from the National Health Research and Development Programme and the Ontario Ministry of Health, respectively. Drs. Naglie and Krahn are partially supported by Arthur Bond Fellowships from the Physicians' Services Incorporated Foundation.

Address correspondence and reprint requests to Dr. Detsky: EN G-246, General Division, The Toronto Hospital, 200 Elizabeth Street, Toronto, ON M5G 2C4, Canada. e-mail: (detsky@utstat.toronto.edu).

for patients presenting with clinical features that suggest giant cell arteritis (GCA). This example is a modification of data found elsewhere.¹

Giant cell arteritis is a vasculitis that affects large and medium-sized vessels, mostly in elderly patients. Patients' symptoms may include headache, fever, and fatigue. When confronted with such a patient, clinicians are faced with diagnostic and treatment options. Giant cell arteritis can lead to a very severe complication of blindness. Steroids are said to decrease the risk of blindness but come with the risk of side effects such as hypertension, fluid retention, and avascular necrosis of bone. There is a test for GCA, i.e., biopsy of the temporal artery can reveal vasculitis in the specimen. However, the sensitivity of that test is not ideal.

We focus on three of the strategies compared in the paper by Buchbinder and Detsky¹: treating no patient with steroids, treating all patients with steroids, and performing a temporal artery biopsy and treating positive cases only.

The Six Recommendations

In the following section we illustrate six recommendations or tips for building a decision model. We have developed these tips for our students and find that if they are followed, it is much easier to build a tree that “functions” appropriately when performing sensitivity analyses. The use of sensitivity analyses to “debug” the tree and determine the robustness of the conclusion is discussed in Part 4 of this series.² For most of the recommendations we show examples of “mistakes” and “correct” ways of modeling the tree. We assume that the reader is fa-

miliar with the usual methods of pictorial display of decision trees.^{3,4}

RECOMMENDATION 1

The tree must have balance. Real clinical problems represent tradeoffs between risks and benefits. The structure of outcomes in a decision analysis must reflect such a tradeoff. If one of the strategic options in the model carries all of the risks and none of the benefits, or, alternatively, all of the benefits and none of the risks, then either the tree is not a valid model of the clinical problem or the clinical problem does not require a decision analysis. Figure 1A shows an example of a model without balance.

Imagine that we are comparing two strategies: 1) treating patients with a specific disease (e.g., GCA) to avoid an adverse outcome (called a “bad outcome”; in this case, blindness) and 2) not treating the patient. The structure of outcomes in both cases includes the possibility of the bad outcome or a good outcome. This is represented after the first probability node in both the upper and the lower

branches of figure 1A. The expression underneath the line represents the probability of the occurrence of that event. If the tree is modeled such that treated patients have a smaller chance of a bad outcome than untreated patients and if the treatment has no down side (e.g., risk of a side effect, inconvenience of compliance with medication), then this tree has no balance. The upper branch clearly dominates the lower branch because it contains all of the benefits and none of the risks.

Figure 1B models the same clinical problem using a tree with balance. First, the therapy arm is associated with a new outcome, the possibility of a major side effect from steroids, such as avascular necrosis of bone. Second, the utilities now reflect not only good and bad outcomes but also the presence or absence of a minor side effect such as fluid retention and a new term denoted “Rx,” which implies the nuisance factor for patients associated with undergoing a therapy. Now each branch has advantages and disadvantages, thereby precluding the decision maker from identifying a strategy that is ideal in all respects.

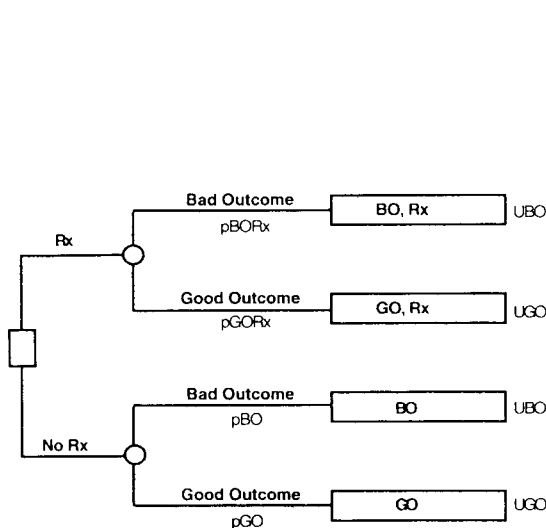

FIGURE 1A. Decision tree without balance.

- pBORx = probability of bad outcome with treatment
- pGORx = probability of good outcome with treatment
- pBO = probability of bad outcome without treatment
- pGO = probability of good outcome without treatment
- UBO = utility of bad outcome
- UGO = utility of good outcome

The bad outcome is blindness. The good outcome is no blindness.

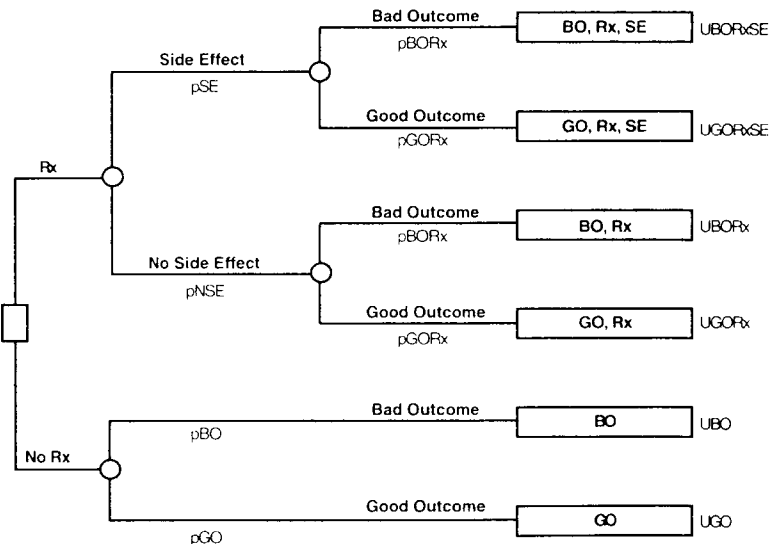

FIGURE 1B. Decision tree with balance.

- pSE = probability of side effect
- pNSE = probability of no side effect
- UBORxSE = utility of bad outcome after treatment and side effect
- UGORxSE = utility of good outcome after treatment and side effect
- UBORx = utility of bad outcome after treatment
- UGORx = utility of good outcome after treatment

The side effect is the side effect of long-term steroid treatment (e.g., hypertension, hyperglycemia, fluid retention, avascular necrosis).

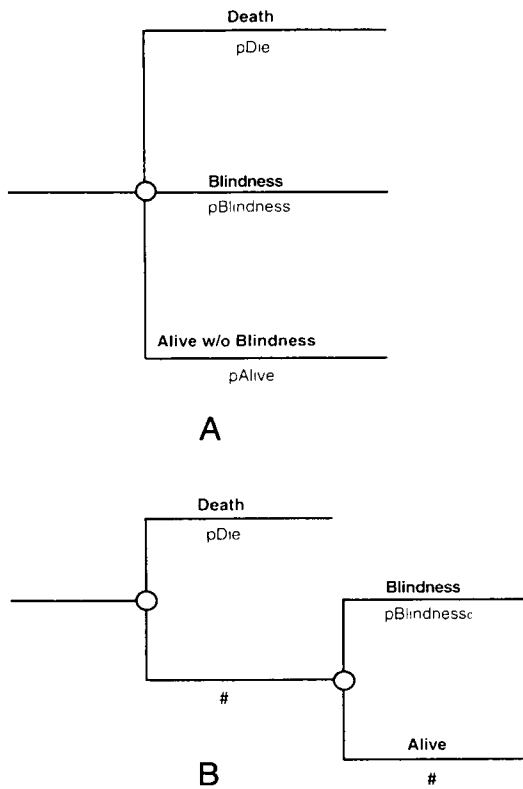

FIGURE 2. A (above), chance node with three outcomes.

- pDie = probability of dying
- pBlindness = probability of blindness
- pAlive = probability of being alive with blindness

B (below), chance nodes with two outcomes.

- # = complement probability (1 minus probability of the upper branches)
- pBlindness_c = probability of blindness, conditional on being alive

RECOMMENDATION 2

Only two branches after each chance node.

Figure 2A represents part of a decision tree reflecting three possible patient outcomes: death, a morbid event (blindness), and life without morbidity. In the baseline analysis, the probability of death (pDIE) is 5%, the probability of blindness (pBlind₁) is 80%, and the probability of being alive without morbidity is 15%. Notice that the probabilities sum to 1. The probability of the last branch after any chance node is called the “complement” of the other branches, implying that it is always numerically equal to 1 minus the sum of the other probabilities.

From a logical and structural point of view, there is nothing wrong with the structure of outcomes as shown in figure 2A so long as the three outcomes are mutually exclusive and exhaustive (the probabilities sum to 1.0). However, when one performs a sensitivity analysis there will be difficulties. For ex-

ample, if the probability of death is allowed to vary between 0% and 40%, the computer will perform the calculations between 0 and 20% only. At this point, the probability of the “complement state” (alive without morbidity) is 0. Once the probability of death exceeds 20%, the three probabilities would sum to a number greater than 1, contrary to the standard laws of probability.

Some software packages will plot the range between 0 and 20% and stop. This will not be a problem if the tree is simple and the analyst can remember that the maximum probability for some of these variables is a value that makes the sum of all probabilities for each branch equal to 1. However, if the tree is complicated it becomes difficult to appreciate all of these constraints in the sensitivity analyses. Furthermore, the computer may impose some constraints that are not evident to the analyst in debugging the tree. Thus, when logical inconsistencies (such as probabilities exceeding 1) arise in sensitivity analyses, it is much more difficult to detect bugs.

Figure 2B displays a method of expressing the structure of outcomes shown in figure 2A while ensuring that the sum of probabilities never exceeds 1. Doing so requires that each probability node be followed by only two branches, with the probability of one branch always expressed as a complement (i.e., 1 minus the probability of the event) of the other branch. Both SMLTREE and DECISION MAKER use the symbol “#” as the complement expression and calculate the lower probability in this manner. Notice that in figure 2B, pBlindness_c is not 80% because it is a probability conditional upon the patient’s being alive. It therefore should be equal to 0.80/0.95, where 0.80 is the unconditional probability of blindness and 0.95 is the unconditional probability of being alive.

RECOMMENDATION 3

No embedded decision node. Figure 3A represents a two-step decision-analytic problem. Imagine that you have a patient who has a given set of signs and symptoms. You may wish to further test the patient, e.g., biopsy the temporal artery, before determining treatment (the upper branch). Alternatively, you may choose to proceed without further testing (the lower branch). If you decide not to test, you are faced with a second decision: should you treat or not treat the patient with a specific therapy (e.g., steroids). Thus, a second decision node is placed in the lower branch. This sequence of reasoning is often natural to clinicians.

Once again, there is nothing illogical about this presentation of a decision tree. However, embedded decision nodes, such as the one shown in the lower

branch of figure 3A, can lead to difficulties in interpreting the sensitivity analyses.

Figure 3C shows a sensitivity analysis that varies the probability of the occurrence of the adverse event without therapy and shows its effect on expected utility in each of the two branches. As is shown in Recommendation 4, most decision models should include a relationship between the probability of an adverse event's occurring with therapy and the probability of an adverse event's occurring without therapy. When the model is built with such a

relationship, the expected utilities of both branches decrease as that probability increases. Interpreting figure 3C, however, is not straightforward. Where the probability of an adverse event is very low, the no-test strategy is best. Where the probability is intermediate, the test strategy is best, and then, once again, as the probability gets even higher, the no-test strategy is best. At first glance this appears counter-intuitive, raising worries about an underlying bug.

Figure 3B shows the preferred way of modeling this problem without an embedded decision node.

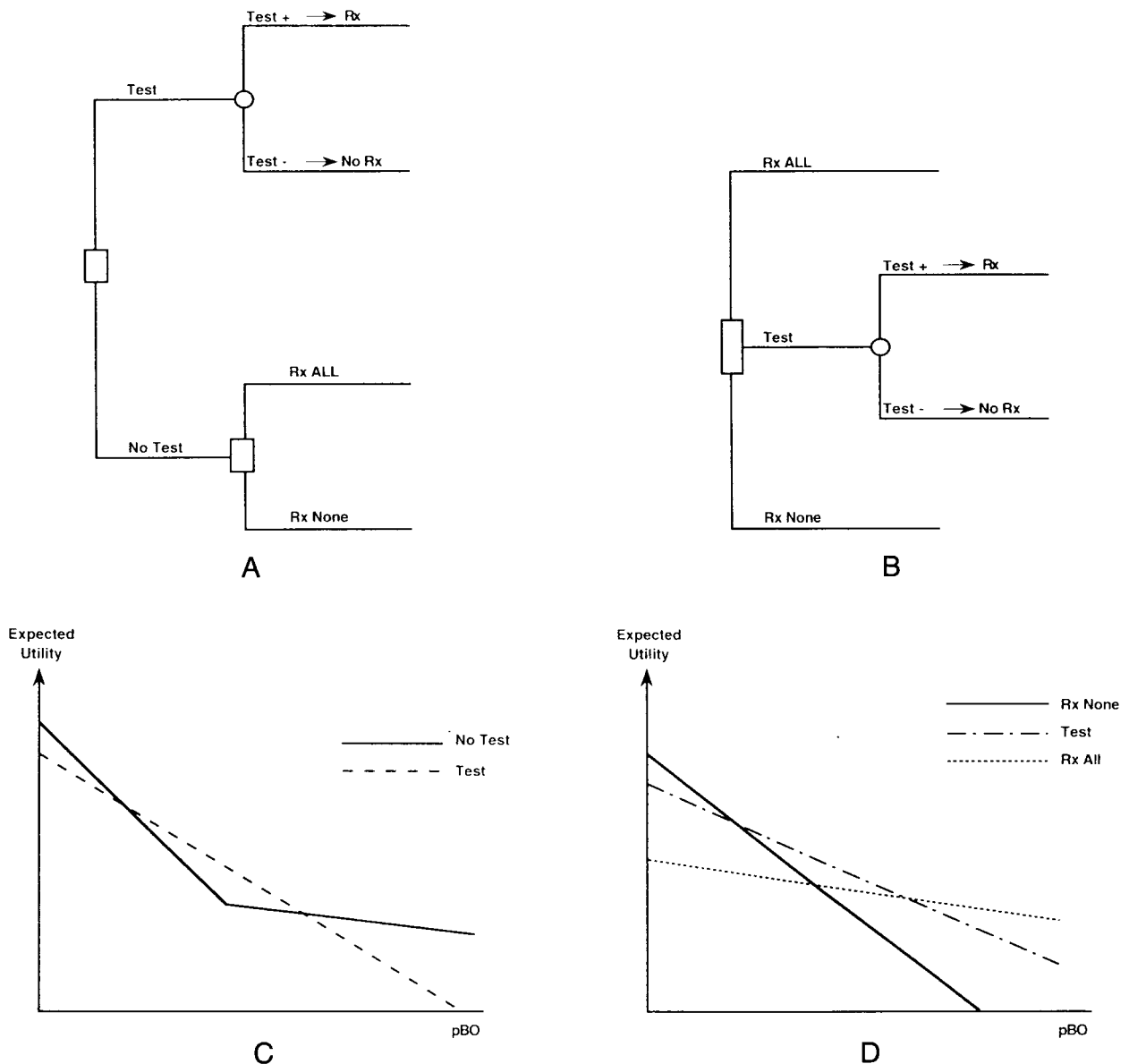

FIGURE 3. A (top left), tree with embedded decision node.

B (top right), tree without embedded decision node.

C (bottom left), one-way sensitivity analysis varying probability of bad outcome (pBO) with embedded decision node.

D (bottom right), one-way sensitivity analysis varying probability of bad outcome (pBO) without embedded decision node.

The no-test strategy is divided into two strategies at the square decision node. There are now three strategies—treat everyone without testing, test and treat only some patients, and treat no patients without further testing. In turn, figure 3D resolves the confusion of figure 3C, showing the relationships between the baseline probability of an adverse event without therapy and the expected utilities for all three branches. The revised display is easy to interpret: at low probabilities the best strategy is to test none and treat none and at the highest probabilities the best strategy is to treat all without further testing.

Once again, interpreting sensitivity analyses for a simple example with a single embedded decision node will not be difficult for most students. However, a small increase in the number of nodes can make interpretation exceedingly problematic. For this reason, we suggest avoiding embedded decision nodes and recommend that all combinations of decisions be expressed as distinct therapeutic strategies coming off the first decision node.

RECOMMENDATION 4

The branches must be “linked.” Figure 4A displays a classic TREAT ALL (labeled Rx All on the tree), TEST AND TREAT SOME (labeled TEST on the tree), and TREAT NONE (labeled Rx NONE on the tree) decision tree. Observe that the probabilities of good and bad events in the three branches are expressed with different variables. For the Rx NONE group, the probability of a bad outcome is called pBO. In the Rx ALL branch, it is called pBORx. The probability of bad outcomes in the TEST branch also has two different expressions, pBOT+ (the probability of a bad outcome given both a positive biopsy and treatment) and pBOT− (the probability of a bad outcome given a negative biopsy and no treatment). Notice also that the probability that a patient will have a “positive test” (e.g., vasculitis evident in the biopsy specimen) is simply expressed as pT+.

Such a model is problematic, for two reasons: First, sensitivity analyses will not yield logical results. As pBO (fig. 4C) increases, for example, the expected utility of the Rx NONE strategy falls, as expected. However, the expected utilities of the other two branches remain the same. It is logically possible that the expected utility of the Rx ALL strategy would remain constant in this circumstance if one simply modeled the probabilities of bad outcomes under conditions of treatment and no treatment as two separate distinct variables with no relationship between the two. However, because there is a subgroup of patients in the TEST strategy that do not undergo treatment, there must clearly be a relationship between pBO and pBOT−. As pBO increases, so too must pBOT−. Therefore, as the expected utility of the Rx NONE

strategy declines as pBO increases, so too must the expected utility of the TEST strategy decline as pBO increases.

The second problem in the model shown in figure 4A relates to invalid probability expressions. Under conditions of no treatment, the probabilities of adverse outcomes in the three branches must be the same. The difference between the Rx ALL and Rx NONE branches lies in the effectiveness of the therapy. However, the middle TEST branch has some patients that are treated and some patients that are not treated. Thus, the overall probability of adverse events in this branch must be a weighted average of the probability of bad outcomes among those patients who have positive tests and the probability of bad outcomes among those who have negative tests, with weights determined by the probabilities of the test outcomes for the patients. One further modification in this weighted average is that some of the patients are treated and therefore have a lower probability of adverse outcomes.

Both problems typified by the model in figure 4A can be remedied by linking probability expressions. Linkage is the explicit relationship among probabilities or utilities in the branches that ought to be related (e.g., the probabilities of a bad outcome in the Rx NONE and Rx ALL branches). Linkage is achieved by designing for the two branches probability or utility expressions that share common variables, thereby allowing both expressions to vary simultaneously when performing a sensitivity analysis on the common variable. Two particularly useful forms of linkage relate to treatment effectiveness and disease probability (prevalence).

Linking the probabilities of outcomes by treatment effectiveness. The first linkage is to create a relationship between the probability of a bad outcome with treatment and the probability of a bad outcome without treatment. Results from clinical trials frequently express this relationship using the term “effectiveness,” which is the proportionate reduction in the probability of an adverse outcome resulting from treatment. Effectiveness, e , is therefore equal to $(pBO - pBORx)/pBO$. By using that expression in the Rx ALL branch, one has a linkage between the Rx ALL and Rx NONE branches that will allow the expected utilities of both branches to fall as pBO rises, as shown in figure 4D.

Linking the outcomes by test characteristics and prevalence (or prognosis). The best way to handle the problem of ensuring linkage between the TEST branch and the other two branches is to use Bayesian expressions incorporating the sensitivity and specificity of the test to reflect its accuracy. Figure 4B shows what those expressions are at each of the probabilities. These can be derived from first principles by examining table 1, which divides all pa-

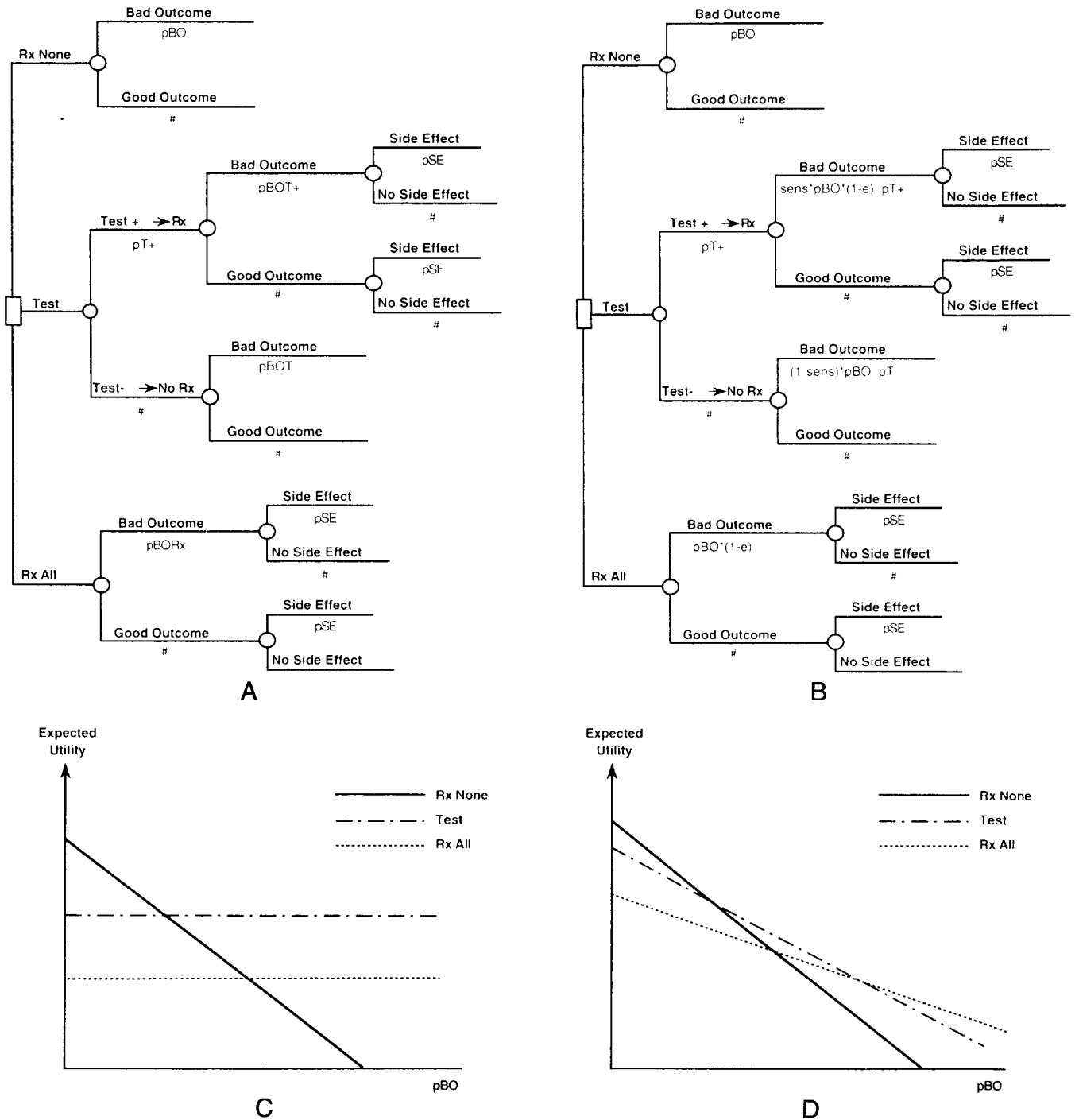

FIGURE 4. A (top left), decision tree without linkages of probabilities.

p_{T+} = probability of positive test

p_{BOT+} = probability of bad outcome if test positive (and patient treated)

p_{BOT-} = probability of bad outcome if test negative (and patient not treated)

The test in our example is temporal artery biopsy.

B (top right), decision tree with linkage of probabilities.

sens = sensitivity of temporal artery biopsy

spec = specificity of temporal artery biopsy

e = effectiveness of treatment

p_{T+} = $(sens \times p_{BO}) + (1 - spec) \times (1 - p_{BO})$

* = multiplied by

C (bottom left), one-way sensitivity analysis where probabilities not linked.

D (bottom right), one-way sensitivity analysis where probabilities are linked.

Table 1 • Bayesian Algebra

	Bad Outcome Will Occur	Bad Outcome Will Not Occur
Test +	$\text{sens} \times \text{pBO}$	$(1 - \text{spec}) \times (1 - \text{pBO})$
Test -	$(1 - \text{sens}) \times \text{pBO}$	$\text{spec} \times (1 - \text{pBO})$
	pBO	$(1 - \text{pBO})$

$$\text{pT}+ = (\text{probability of positive test}) = [(\text{sens} \times \text{pBO}) + (1 - \text{spec}) \times (1 - \text{pBO})]$$

$$\text{pT}- = (\text{probability of negative test}) = [(1 - \text{sens}) \times \text{pBO} + (\text{spec}) \times (1 - \text{pBO})]$$

sens = sensitivity of temporal artery biopsy

spec = specificity of temporal artery biopsy

pBO = probability of bad outcome

$$\text{Positive predictive value} = (\text{sens} \times \text{pBO}) \div \text{pT}+$$

$$\text{Probability of BO if test negative} = [(1 - \text{sens}) \times \text{pBO}] \div \text{pT}-$$

tients in a sample into four cells in a 2×2 table. The essential feature is to obtain posttest probabilities as a function of the baseline disease probability.

By examining the expressions in the four cells of table 1, the reader can reconstruct the probabilities shown in the TEST branch of figure 4B. For example, $\text{pT}+$, the probability for the upper branch following the first chance node in the TEST branch, is equal to the sum of the probabilities shown in the upper row of table 1 (also shown in the legend). For the following chance node, labeled BAD OUTCOME, the probability equals the expression for positive predictive value (see table 1 footnote), multiplied times $(1 - e)$, the proportionate reduction in the risk of a bad outcome because the patient is treated. As an exercise, our students are asked to recreate the expressions in figure 4B from first principle using table 1.

RECOMMENDATION 5

The tree must have symmetry. Another feature in the tree structure of figure 4B is "symmetry." Symmetry means that all underlying initial health states that could affect outcomes are represented in all branches. We believe that a tree must have symmetry among the branches to simplify interpretation of sensitivity analyses. Thus, portions of the tree structure are repeated in the various strategic branches. The use of subtrees is one strategy that ensures symmetry and reduces the risk of programming errors. In figures 4A and 4B the structure of outcomes for the Rx NONE group is repeated both in the Rx ALL branch and in a portion of the TEST branch (for those patients who have negative tests). Similarly, the structure of outcomes for the Rx ALL

patients is repeated in the TEST branch (for those patients who have positive tests).

Those who use SMLTREE or DECISION MAKER will notice that these software programs easily allow linkage and symmetry. In the simplest case, linkage between branches can be achieved by programming the probabilities (or utilities) as expressions containing common variables. A more complex method that ensures both linkage and symmetry is to build a subtree. A subtree is a part of the tree whose structure is repeated at more than one location in the whole tree. For example, figure 4B contains two subtrees. The first is the structure of outcomes that follows the label Rx NONE that is repeated after a negative test result, the lower branch of the TEST strategy. The second is the structure of outcomes that follows Rx ALL that is repeated after a positive test, the upper branch of the TEST strategy.

In SMLTREE the programmer uses the LINK command to repeatedly place that subtree in appropriate places. The computer will copy the structure every place the same branch name is used with the LINK command. By doing so, however, the computer will also copy identical probabilities and utilities for all the branches distal to that point, and, as can be seen in figure 4B, the probabilities for the branches of the subtree in the TEST branch are different from those in the other two branches. To vary the subtree probabilities and utilities for different parts of the tree, the programmer can use temporary bindings at a point to the left of the subtree that will alter these variables from that point on for that branch alone. Temporary bindings are statements placed at various points in the tree that alter the values that variables (i.e., probabilities and utilities) take on for all distal points in the tree. They differ from global bindings, which set the initial values for these variables for all points in the tree unless they are temporarily bound.

For example, after copying the subtree following Rx NONE at the top of figure 4B (bad or good outcome) on to the lower branch of the TEST strategy representing a negative test (called T → No Rx in figure 4B), one should temporarily bind the variable pBO at the T- node to $(1 - \text{sens}) \times \text{pBO} \div \text{pT}-$. This changes the value that pBO takes on for all parts of the tree to the right of that temporary binding. In SMLTREE this is best done by creating a branch called T-, making it a label node (a node that is followed by only one outcome), and then following it with the subtree Rx NONE using the LINK function. The temporary binding noted above is then placed at T-. One can use temporary bindings and subtrees throughout to incorporate the principles of both linkage (recommendation 4) and symmetry (recommendation 5).

FIGURE 5. Reverse order of bad outcome and test result.

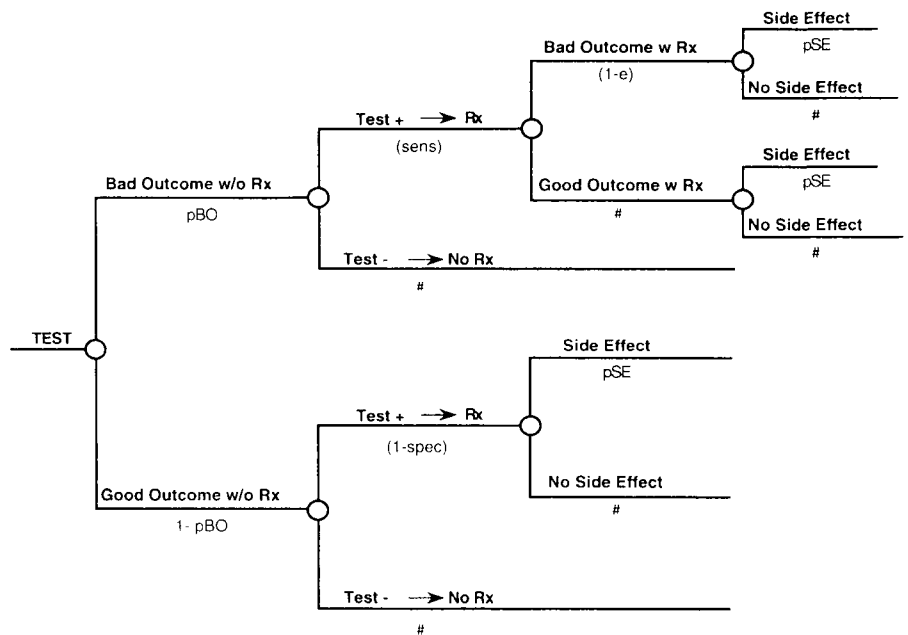

RECOMMENDATION 6

Don't worry about order. Many individuals who are trying out decision analysis for the first time worry about the order of the outcomes within the structure of outcomes for each branch. Should we model the adverse events resulting from disease (e.g., blindness) before the side effects of therapy (e.g., avascular necrosis from steroids)? Should we order the probability of disease before the test results or after them?

The answer to this question is: It doesn't matter. The reason it doesn't matter is easy to understand, in that the process of determining the expected utility for each branch is determined by folding back the tree. Mathematically, this is equivalent to multiplying all of the probabilities along the branches until one obtains the probability of being in each state of the terminal nodes. One then uses these products of probabilities as the weights to derive the expected value, i.e., multiplying the product of probabilities by each of the utilities and then summing that over all outcomes for each branch. Once one understands the folding-back process, sequence does not matter because of transitivity, $a \times b = b \times a$.

Figure 5 shows a variation of figure 4B that flips the order of the test results and the outcomes. In figure 4B the test results are modeled before the adverse outcomes. In figure 5 the underlying probability of a bad outcome for the patient is modeled first, and once again one relies on table 1 to derive the probability that patients will have a bad outcome, namely the sum of the upper left and lower left boxes of table 1. In figure 5 the effectiveness fac-

tor and side-effect risk are included only for patients who are treated, i.e., those who have positive tests.

It is sometimes very useful to model trees showing the underlying distribution of disease or adverse events, as shown in figure 5, by placing that probability as the first chance node. This process will ensure that the underlying distribution of disease or adverse events (bad outcomes) is the same in the three branches, which must be true in order to make the tree behave correctly when doing sensitivity analyses. In implementing this process, we have found that beginners in decision analysis had difficulty accepting these trees because, as they state, "But you don't know whether the patient does or does not have the disease before you do the test." Recommendation 5 helps them understand that the order does not matter and therefore they need worry about not what the clinician actually knows, but rather how the tree will operate in terms of keeping the distribution of patients constant in the three branches. In fact, for individual patients, you don't know whether they have the disease, but you do know the probability distribution. Nevertheless, the layouts of trees may have an impact on those who read papers about decision analysis, and this should be kept in mind when presenting such material to clinicians, who may not understand that order doesn't matter.

Giant Cell Arteritis—Example

As mentioned above, in this series of papers, we use a common example of management strategies for patients with suspected giant cell arteritis. Figure

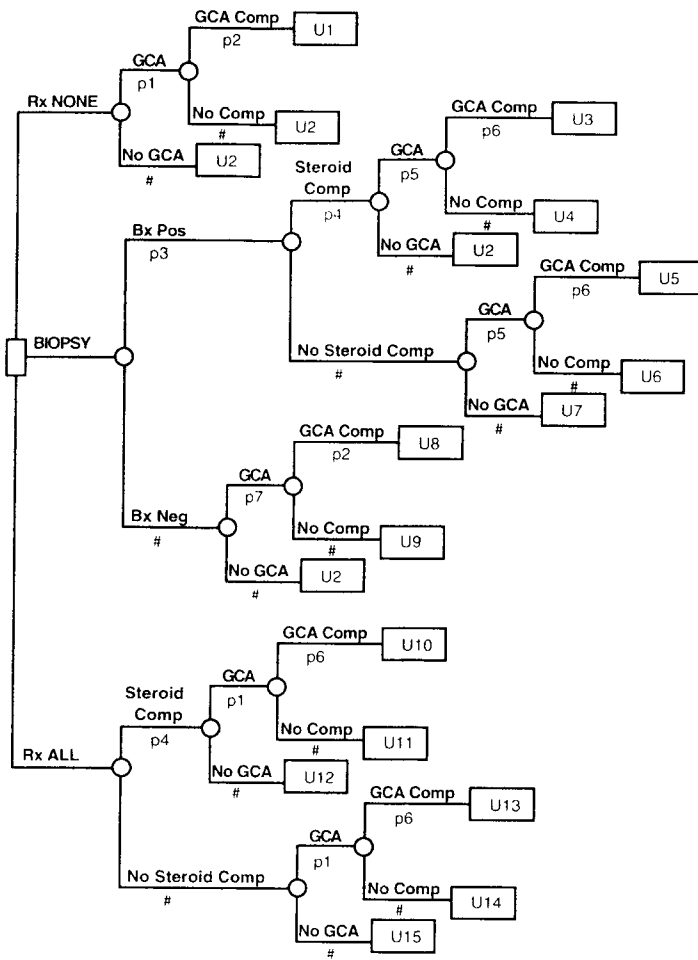

FIGURE 6. Strategies for patients with suspected temporal (giant cell) arteritis.

- GCA = giant cell arteritis
- GCA comp = giant cell arteritis complication (i.e., blindness)
- Steroid comp = steroid complication
- p1 = probability patient has GCA
- p2 = probability of GCA complication without steroids (pCGA comp) given that the patient has giant cell arteritis
- p3 = probability of positive temporal artery biopsy = $\text{sens} \times p1 + (1 - \text{spec}) \times (1 - p1)$
- sens = sensitivity of biopsy
- spec = specificity of biopsy
- p4 = probability of steroid comp
- p5 = probability of GCA in patients with positive temporal artery biopsy = $(\text{sens} \times p1) \div p3$
- p6 = probability of GCA comp given that the patient has GCA and is treated with steroids = $p2 \times (1 - e)$
- p7 = probability of GCA for patients with negative biopsy = $[(1 - \text{sens}) \times p1] \div (1 - p3)$
- U1 to U15 = utilities for the individual states
- Bx Pos = biopsy positive for GCA
- Bx Neg = biopsy negative for GCA

6 displays the tree that we use for the example. It is a modified version of the tree used by Buchbinder and Detsky.¹ We have simplified the tree somewhat for the purposes of this series in order to illustrate principles of decision analysis.

The reader will notice that the tree follows all of the six recommendations listed above and is a variation on the three common strategic choices Rx NONE, Rx ALL, and TEST and treat some. The top branch displays the common structure of the patient's developing a complication of giant cell arteritis or not without treatment. This structure is repeated as a subtree throughout the tree with variations in the complication rate occurring depending on the biopsy test result and whether or not the patient received treatment. In the bottom or Rx ALL branch, the possibility of a steroid complication is introduced, with the offsetting benefit of a reduced risk of a complication of giant cell arteritis because of steroid treatment. The middle or BIOPSY branch divides the patients into those with positive and negative biopsy results. Bayesian algebra is used as in the generic example shown in figure 4 to divide the patients into groups at higher and lower risk for developing complications of giant cell arteritis. Those whose biopsy results are positive are treated, thereby reducing the risk of complications but exposing the patients to the complications of steroid use. The probabilities throughout the tree are described in the legend; the utilities are simply numbered for further discussion in Part 3⁵ of this series.

References

1. Buchbinder R, Detsky AS. Management of suspected giant cell arteritis: a decision analysis. *J Rheumatol.* 1992;19:1220-8.
2. Krahn MD, Naglie G, Naimark D, Redelmeier DA, Detsky AS. Primer on medical decision analysis: Part 4—analyzing the model and interpreting the results. *Med Decis Making.* 1997; 17:142-51.
3. Richardson WS, Detsky AS, and the Evidence-Based Medicine Working Group. Users' guides to the medical literature. VII. How to use a clinical decision analysis. A. Are the results of the study valid? *JAMA.* 1995;273:1292-5.
4. Richardson WS, Detsky AS, and the Evidence-Based Medicine Working Group. Users' guides to the medical literature. VII. How to use a clinical decision analysis. B. Results and applicability. *JAMA.* 1995;273:1610-3.
5. Naglie G, Krahn MD, Naimark D, Redelmeier DA, Detsky AS. Primer on medical decision analysis: Part 3—estimating probabilities and utilities. *Med Decis Making.* 1997;17:136-41.

Glossary

Debugging: A process whereby the analyst performs a series of sensitivity analyses with the programmed model in order to determine where errors exist.

Bugs: A term for an error in the tree.

Robust: An analysis is robust if the qualitative conclusion (e.g., that therapy A is better than therapy B) is insensitive to the uncertainties in the analysis such as quantitative estimates of probabilities or utilities.

Embedded decision nodes: Decision nodes that appear anywhere within the tree except at the leftmost position of the tree.

Linkage: The explicit relationship(s) (by the use of algebraic expressions) among probabilities or utilities in the various branches of the tree that ought to be related (e.g., the probabilities of a bad outcome with and without treatment).

Symmetry: All underlying health states that could affect outcomes are represented in all branches of the tree. Symmetry

is achieved by repeating the structures of portions in the various branches via the use of subtrees.

Subtree: A portion of the model that is repeated in various places throughout the tree. The programmer can use the "LINK" function to copy subtrees at various locations.

Global values: This expression is related to SMLTREE and DECISION MAKER and refers to the quantitative estimates for all variables found in the variable list. These values are then applied throughout the tree at all times except where temporary bindings override them.

Temporary bindings: Reassigned values of quantitative estimates for specific variables that override the global bindings at various points throughout the tree. This function is particularly useful when subtrees are placed throughout the tree but quantitative estimates of the variables must differ at the various locations.

Label node: A node that has only one node following it occurring with 100% probability. This is a useful technique for combining subtrees with temporary bindings as it is a good place for the temporary bindings.

ANNOUNCEMENT

Executive Programs in Medical Education Harvard School of Public Health, Center for Continuing Professional Education

Fee: 1995 (\$1,295 academic & government)

Cost-Effectiveness Analysis for Medical Technologies and Pharmaceuticals

June 9–12, 1997

PROGRAM DIRECTORS

Milton C. Weinstein, PhD
Henry J. Kaiser Professor of Health
Policy and Management and
Biostatistics
Director, Program on the Economic
Evaluation of Medical Technology
Harvard Center for Risk Analysis
Harvard School of Public Health

Peter J. Neumann, ScD
Deputy Director, Program on the
Economic Evaluation of Medical
Technology
Harvard Center for Risk Analysis
Harvard School of Public Health

You will learn to develop and design economic evaluations in clinical trials specifically suited to your organization's purpose at this advanced program. For further information contact Nicole Costa, tel: 617-432-1171; fax: 617-432-1969; e-mail: <contedu@sph.harvard.edu>.